

Universal Motion Components

Quality Irrigation Products

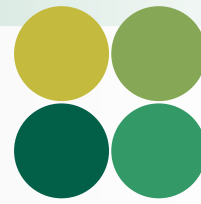

UMC is a ISO 9001:2015
Certified Company



UMC

www.umcproducts.com

2920 Airway Ave, Costa Mesa, Ca. 92626
phone: 714.437.9600 fax: 714.437.9700

Final Drive Gearbox

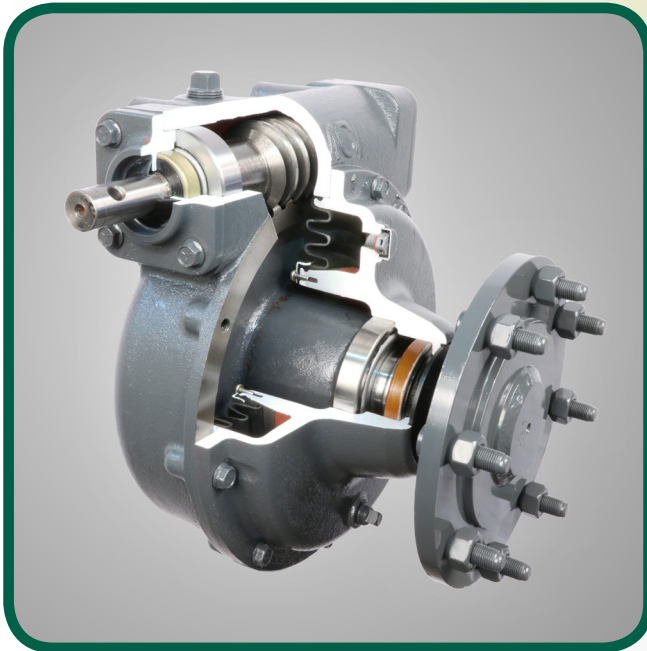

765-U-AD™ Gearbox

Designed for heavy spans, extreme conditions, corner systems, and lateral / linear carts

The UMC® 765-U-AD™ gearbox is designed for use on center pivots and lateral / linear irrigation systems. It is typically used for the most extreme conditions and applications such as corner systems, lateral carts and heavy towers. It is the ideal choice for areas where extreme field conditions exist and/or machines run high annual hours of operation.

Part Number	Ratio
10162-105A	50:1

Features and Benefits

The patent pending UMC® 765-U-AD™ gearbox is our largest and most durable high performance gearbox with a 50:1 gear ratio. It is a direct replacement for its predecessor, the 760-U™, and features several improvements that enhance load capacity, gear life and seal life.

- ▶ 2.50" diameter steel output shaft
- ▶ 50:1 gear ratio
- ▶ Cartridge input and output seals
- ▶ Patent Pending Vented Internal Diaphragm with large expansion cavity for near zero psi pressure accumulation which increases seal life and reduces oil leaks
- ▶ Enhanced gear material that increases load capacity, reduces gear wear and lowers operating temperatures, extending gear life
- ▶ 16-Bolt mounting pattern
- ▶ External seal protectors for input and output seals
- ▶ Largest output bearings in the industry
- ▶ Dual ended input shaft with hub cap for the unused end
- ▶ Top oil fill plug
- ▶ Filled with extreme pressure gear oil
- ▶ Extra long carriage bolts allow use with reinforced rims
- ▶ Positive wheel register
- ▶ Bronze gear optional

sales@umcproducts.com

Universal Motion Components

Dimensional Drawing

765-U-AD™ Final Drive Gearbox

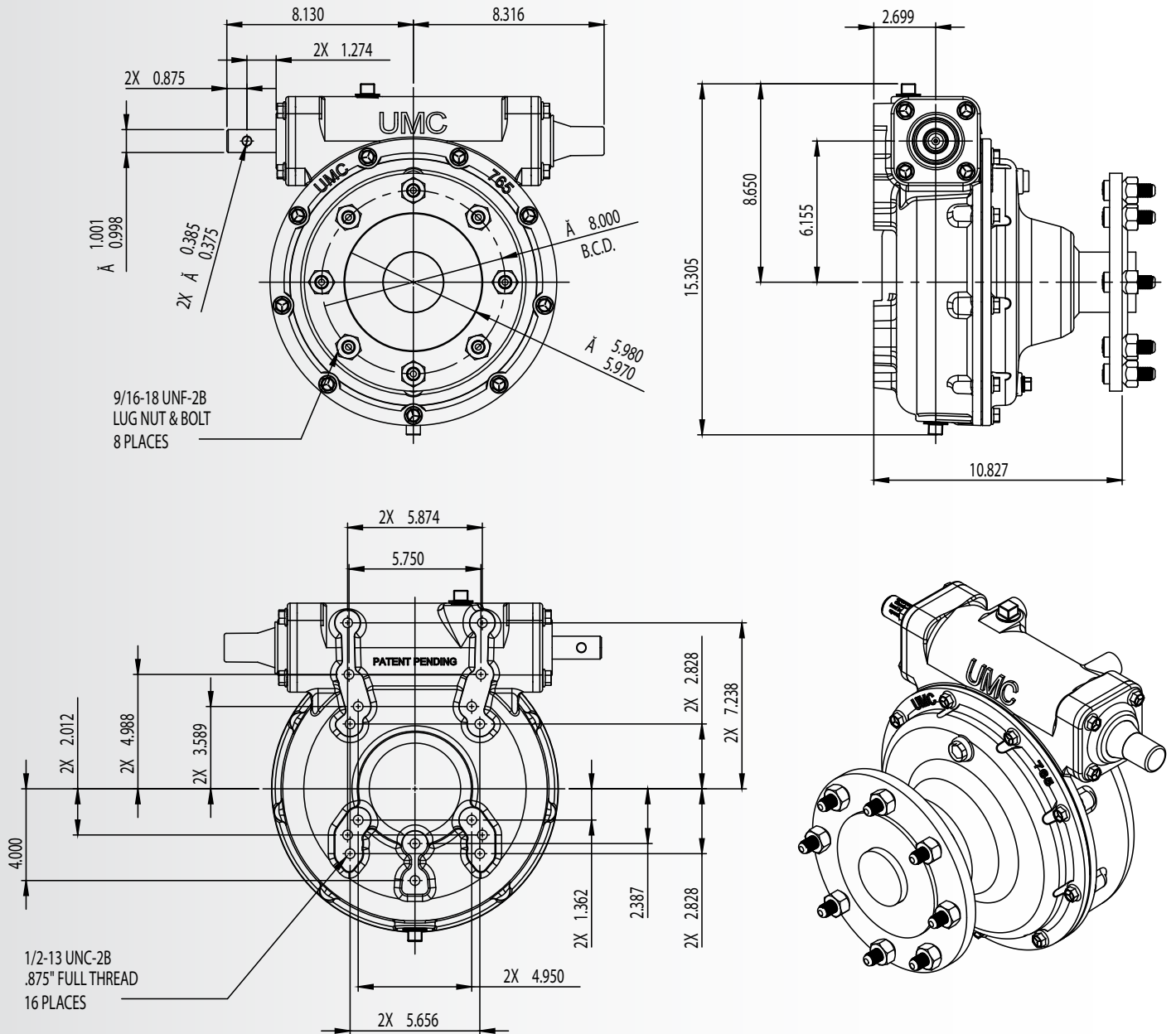

sales@umcproducts.com



www.umcproducts.com



Universal Motion Components, Co. Inc.
2920 Airway Ave, Costa Mesa, Ca. 92626
Phone - 714-437-9600 Fax - 714-437-9700
Web - <http://www.umcproducts.com>
E-mail - sales@umcproducts.com